

# ECONOMY LEVER HOIST, ELH-30-10

\*\*\* ANY ADDITIONS, DELETIONS, OR OMISSIONS MUST BE CORRECTED ON THIS DRAWING AS THIS DRAWING WILL BE CONSIDERED ALL INCLUSIVE \*\*\*  
 ALL GRAPHICS PROVIDED ARE FOR REFERENCE ONLY. IF CERTAIN DIMENSIONS ARE CRITICAL PLEASE VERIFY THOSE DIMENSIONS WITH YOUR SALESPERSON

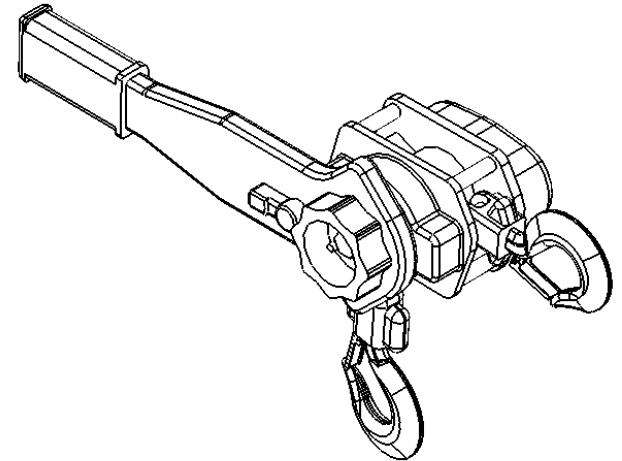
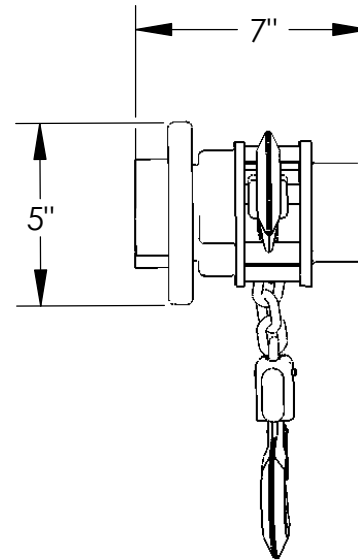
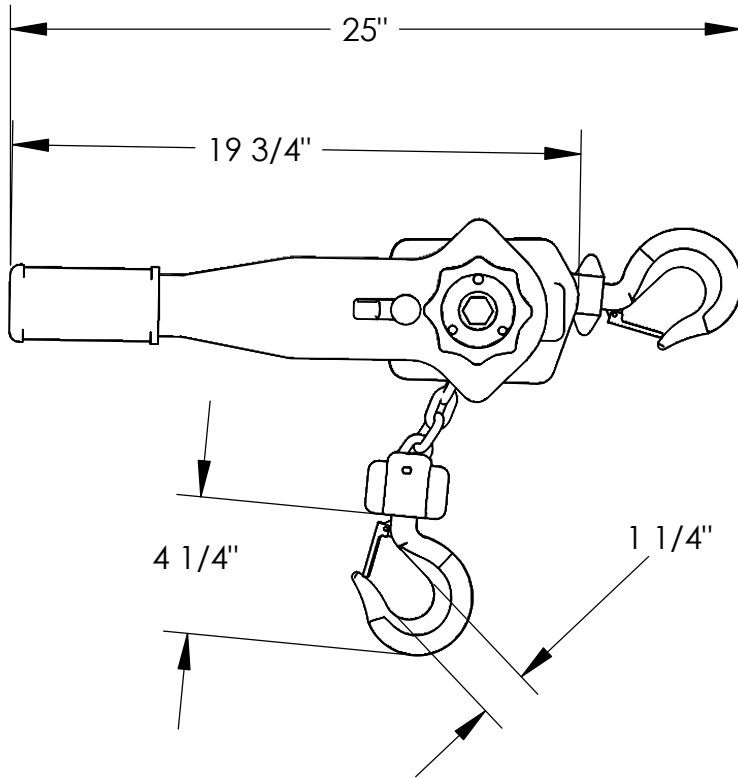

## STANDARD FEATURES

MODEL NUMBER IS ELH-30-10  
 CAPACITY IS 3,000 LBS.  
 STANDARD LIFT IS 10' (FEET)  
 MAXIMUM DISTANCE BETWEEN HOOKS IS 15"  
 HANDLE LENGTH IS 16"  
 OVERALL LENGTH IS 25"  
 OVERALL WIDTH IS 7"  
 OVERALL HEIGHT IS 5" (EXCLUDING CHAIN & HOOK)  
 BAG-12 INCLUDED (NOT SHOWN)

## SPECIAL FEATURES

NONE

## APPROVAL

I, the undersigned, hereby approve this print

[ ] As drawn [ ] As marked

This includes my approval of design & dimensions

Signed: \_\_\_\_\_

Date: \_\_\_\_\_

DISTRIBUTOR'S NAME: <b>VESTIL MANUFACTURING</b>		P.O.#
DRAWN BY: <b>SR</b>		W.O.#
DATE: <b>4-19-07</b>		SALES:
LEAD TIME WILL START UPON		FILE NAME: <b>ELH-30-10</b>

**SolidWorks Detached drawing - Out-of-Sync Print**